

REFERENCE MANUAL - **ENGINEERING**

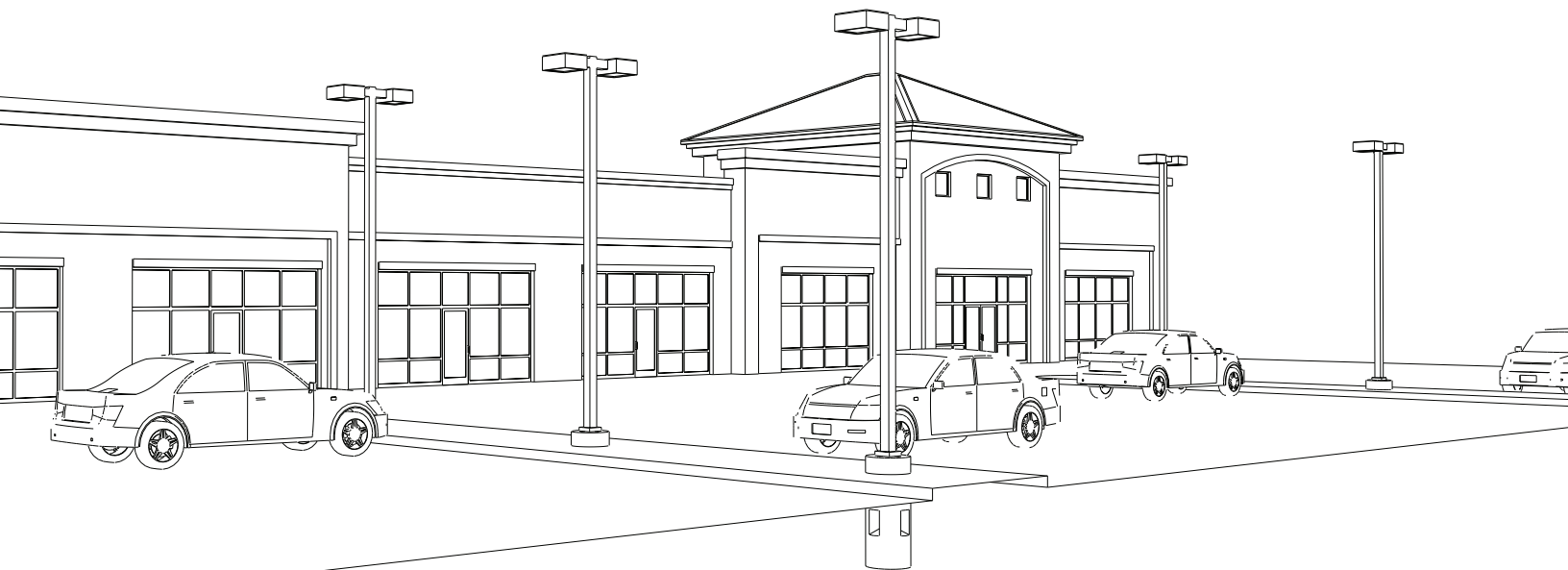

The Future of Precast **Light Pole Bases**



Visit lightpolebase.com for more information.

Produced by ReCon Wall Systems, Inc.

Version 2.1 - July 2019

© Copyright 2019 All Rights Reserved

Table of Contents

Product Overview

The LPB	6
---------------	---

Design Approach

Overview	10
Anchoring System Analysis	10
Foundation Analysis	13
Design Example	15

Design Tables

Overview and Assumptions	26
How to use the LPB Design Tables	27
105 mph, Exposure C	28
120 mph, Exposure C	33
130 mph, Exposure C	38

Product Drawings

LPB Typical Layout	44
LPB Anchoring System	45

Appendix A

LPB Anchoring System Testing Report	48
---	----

Appendix B

LPB Independent Review Letter	56
-------------------------------------	----

References	58
------------------	----

Disclaimer	59
------------------	----

Product Overview

The LPB

The LPB is a universal precast concrete light pole foundation that offers several distinct advantages over other precast pole foundations as well as cast-in-place concrete foundations.

Adjustable Anchoring System

The Anchoring System, which is embedded into the top of the LPB, utilizes four ¾-inch diameter threaded rods and can accommodate bolt circle diameters as small as 7-½-inches and as large as 13-½-inches. This allows for the installation of a variety pole sizes and shapes, sure to fit most commercial light pole base plate configurations.

Large Side Openings and Central Pathway

The LPB contains four large side openings that lead to a central vertical pathway sleeve. The size and location of the openings along with the pathway sleeve allow for flexibility and ease of electrical conduit installation from multiple directions.



In Stock and Available

Because the LPB has a standard size and configuration, designed to accommodate a variety of pole sizes and shapes, it can be produced in advance without knowing the specifics of the project. This reduces product lead times and allows for flexibility if project requirements change.

Installation Efficiency

The LPB is cured and ready for installation when it arrives to the jobsite. Light poles can be installed within hours, rather than days, once the base has been set and backfilled. Less coordination between the installer and electrician is required and onsite construction effort has been minimized since the LPB does not require any formwork or tying of rebar in the field.

Quality

Because the LPB is produced by trained personnel in a controlled environment, a high-quality product can be maintained. Mix designs are documented and quality assurance programs are followed, resulting in a predictable and consistent product.

Design Approach

Overview

The design of a LPB is completed by analyzing two distinct portions of the foundation. The first is the Anchoring System that is embedded into the top of the foundation and the second is the concrete foundation itself. The Anchoring System within the LPB consists of four slots, created by plastic inserts, each containing an anchoring nut that is located approximately 4-½-inches below the top concrete surface. The procedures below outline the steps taken to complete the analysis of the Anchoring System and the concrete foundation.

Anchoring System Analysis

Step 1A

The first step in the analysis of the Anchoring System is to establish the dimensional parameters for the pole and the luminaires that will be attached to the top of the foundation. For the pole this includes the height, shape (round or square) and width or diameter. For the luminaires, this includes the Effective Projected Area (EPA), if known, or the contact/surface area and shape (flat or rounded sides) if the EPA is unknown.

Step 2A

The second step in the process is to calculate the maximum wind pressures that will be acting on the pole and luminaires. The American Association of State Highway and Transportation Officials (AASHTO) publication: LRFD Specifications for Structural Supports for Highway Signs, Luminaires, and Traffic Signals, First Edition, 2015 (LRFDLTS-1) outlines the process for determining the maximum wind pressure acting on the pole and luminaires. The wind pressure is calculated using a basic wind speed, a wind exposure category and several other calculated coefficients/factors. Additional information regarding the calculation of wind pressure can be found in Chapter 3 of the AASHTO manual referenced above.

It is important to understand, that the Basic Wind Speed chosen as part of this step is based upon a Mean Recurrence Interval, Risk Category and location which must be established by the Designer. Determining the Basic Wind Speed is a critical step as it will greatly affect the amount of load transferred to the LPB Anchoring System. Additionally, the AASHTO LRFDLTS-1 considers wind to be an extreme event with a Load Factor of 1.0. Therefore, the wind pressures calculated as part of this step will not be increased further in subsequent steps.

Step 3A

The third step consists of calculating the base reactions, or moment and shear at the base of the pole. This is completed by multiplying the effective area of the pole and the luminaires by the respective wind pressures that were determined in Step 2A. Additionally, since this is an LRFD design, the total moment and shear are multiplied by a Load Factor. As mentioned above, since wind is considered an Extreme Load, the Load Factor is 1.0 according to AASHTO Table 3.4-1.

Step 4A

Once the base reactions have been determined the tension in the individual bolts can be calculated. At this point in the process, a bolt circle diameter will need to be chosen. The LPB allows for bolt circle diameters ranging from 7-½-inches up to 13-½-inches. Each bolt circle consists of four (4) ¾-inch diameter threaded rods that are attached to the anchoring nuts within the inserts. The bolt circle diameter has a direct effect on the resulting bolt tension which is then transferred to the anchoring nut. Choosing a bolt circle diameter is a critical step and may be iterative as several diameters may need to be examined in order to satisfy the requirements of subsequent Steps. The bolt circle diameter is limited to no more or less than four (4) bolts and it is also important to keep in mind that the bolt circle diameter may be a set value based upon the proposed light pole that will be installed. In this case, refer to the light pole manufacturer for additional information.

The Total Tensile Load within a given bolt is based upon the following:

- Moment at the base of the pole
- The centroid distance to each bolt
- The moment of inertia of the bolt group
- And the stress area of the bolts

The example and Figure 1 below illustrate the calculation process for determining the tension in the bolts.

$$\text{Centroid Distance to Bolts} = c = \frac{d}{2} \cdot \cos 45$$

$$\text{Tensile Stress Area of Each Bolt} = A_T = \frac{\pi}{4} \cdot \left[d_b - \frac{0.9743}{n} \right]^2$$

$$d_b = \text{bolt diameter} = 0.75 \text{ in}$$

$$n = \text{threads per inch} = 10$$

$$A_T = 0.334 \text{ in}^2$$

$$\text{Moment of Inertia of Bolts} = I = \sum A_T \cdot c^2 = 4 \cdot A_T \cdot c^2$$

$$\text{Bolt Stress} = \frac{\text{Moment} \cdot c}{I}$$

$$\text{Bolt Tension} = T_u = \frac{\text{Bolt Stress}}{A_T}$$

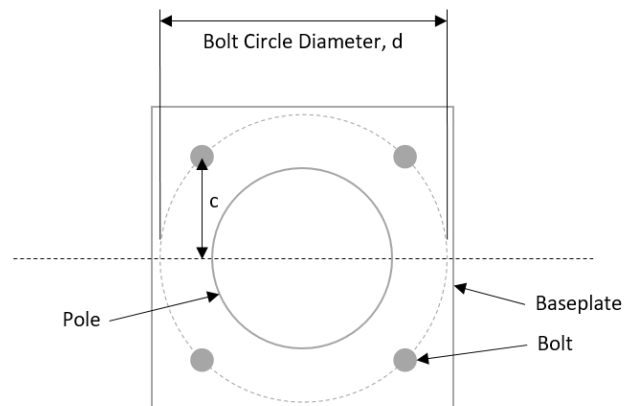

Figure 1

For additional information regarding the procedure outlined above, refer to the National Cooperative Highway Research Program document NCHRP Report 412.

Step 5A

The next step in the analysis process is to check the adequacy of the Anchoring System. Given the proprietary use of the inserts and anchoring nuts, load testing of the Anchoring System was completed in order to determine the nominal tensile capacity. A full write-up of the testing completed is contained in Appendix A.

In total, 12 tests were completed at three different bolt circle diameters; 14-inches, 10-inches, and 7-½-inches. In each test, the anchor was loaded to 18,500 pounds which was a predetermined value based upon the actual anticipated loads. In all 12 tests, the Anchoring System held the applied load without failure. Based upon these results, LPB recommends using 18,500 pounds as the nominal tensile capacity of an individual anchor bolt within the Anchoring System.

According to the Chapter 5 Section 5.16.3 of the AASHTO LRFDLTS-1 manual, resistance factors for concrete anchorages shall be as specified in ACI 318-11, Appendix D. Section D.4.3 of ACI 318-11 specifies that for anchors governed by concrete breakout, side-face blow-out, pullout, or pryout (which is typically how the LPB Anchoring System performed) a reduction factor of 0.7 should be used for tension loads.

Step 5A within the analysis process compares the nominal tensile capacity, with reduction factor, to the applied load that was calculated in Step 4A. If the applied load exceeds the reduced nominal capacity, a different pole and bolt circle configuration will be required to reduce the applied load.

Step 6A

According to the AASHTO LRFDLTS-1 manual and National Cooperative Highway Research Program (NCHRP) Report 469, anchor rods subject to more than 20,000 repeated applications of significant axial tension shall be checked for the fatigue limit state. This step begins the process of analyzing the system for fatigue loading. In Step 2A, the wind pressure that was calculated is considered the ultimate design load. In addition to analyzing for this load condition, fatigue must be considered using a lower wind pressure.

Step 6A consists of determining the resulting bolt stress based upon the pressure generated from Natural Wind Gusts. The Natural Wind Gust pressure is calculated using the Yearly Mean Wind Velocity, the drag coefficients for the pole and luminaires, and an Importance Factor, which is based upon a Fatigue Category. The equation for determining the Natural Wind Gust is based upon a Yearly Mean Wind Velocity of 11.2 miles per hour. If an alternate velocity is known, it may be used accordingly. For more information on the selection of the Fatigue Category, and resulting Importance Factor, refer to Section 11.6 of the AASHTO LRFDLTS-1.

For the purposes of this analysis process, truck-induced gusts and galloping have been ignored given the anticipated installation locations and pole/luminaires configurations to be used with the LPB. If either of these loading conditions are anticipated, given the actual site conditions, further analysis is recommended.

Step 7A

The final step in the Anchoring System analysis process is to check the anchor rods with respect to the fatigue bolt stress that was calculated in Step 6A. The NCHRP Report 469 defines the stress range as the magnitude of the change in nominal stress due to the application or removal of the unfactored live load. The S-N curve for galvanized non-pretensioned anchor rods corresponds to detail Category E', however the fatigue threshold is much greater than other Category E' details. Therefore, in the case of anchor rods a threshold of

7000 psi is recommended per the NCHRP report. This is the value that is compared to the stress that was calculated in Step 6A. The NCHRP report states that no further evaluation of fatigue resistance is required if the stress in the anchor rod remains below the threshold stress range. However, LPB recommends that an additional check be completed. The additional check compares the combined fatigue tension and ultimate design tension to the reduced nominal capacity of the Anchoring System. This check is not prescribed in any Code or industry document but is merely a recommendation and may be used at the Designer's discretion.

It is worth noting that the NCHRP Report 469 states: "In steel-to-concrete joints subject to fatigue, the anchor rod will fail before the concrete fatigue strength is reached. Therefore, it is not necessary to consider the fatigue strength of the concrete." Based upon this statement, no additional fatigue analysis of the concrete Anchoring System has been completed.

Finally, it is possible to meet the requirements of Step 5A, based upon the chosen bolt circle diameter, but not meet the requirements of Step 7A. If this is the case, a larger bolt circle diameter will need to be used in Step 4A, if possible, and then the rest of the process re-analyzed.

Foundation Analysis

Step 1B

The first step in the foundation analysis is to establish the dimensional parameters for the foundation. This includes the total foundation length, the above grade length, shape, and diameter or width. The LPB has a minimum total length of 4-feet and a maximum of 10-feet. The foundation is generally produced in even 1-foot increments and the amount of above grade length may vary depending on analysis and project requirements. Finally, the standard shape for the LPB is round with an above and below grade diameter of 24-inches. If foundation dimensions outside of the typical parameters stated are needed to meet the project requirements, contact LPB and/or the producer to discuss possible options.

It should be noted that determination of the total length and above grade length may become an iterative process based upon remaining analysis that is completed.

Step 2B

The next step is to establish the parameters for the soils in which the foundation will be buried. The first parameter, which is critical to the analysis process, is to determine if the soils are cohesive or cohesionless. The primary difference between these soils types is in how the shear strength of the soil is determined. For cohesive soils, the shear strength is based upon cohesion or the attraction forces between the soil particles. For cohesionless soils, the shear strength depends on the internal friction angle of the soil particles. Cohesive soils are typically fine-grained soils such as clays and silts where as cohesionless soils are generally sands and gravels.

After the soil type has been defined, internal friction angle, soil unit weight, and cohesion will also need to be established. Most often these values will be obtained from a Geotechnical Report if one has been prepared for the project. If a report is not available, it is recommended that a geotechnical engineer be consulted to aid in the determination of the specific soil parameters.

Step 3B

Once the foundation and soil parameters have been established, the ground line reactions can be calculated. The total unfactored moment and shear, at the base of the foundation, are determined using surface area of the foundation, pole and luminaire multiplied by a wind pressure that is specific to each component. The wind pressures are determined in the same manner as outlined in Step 2A of the Anchoring System Analysis and in accordance with AASHTO LRFDLTS-1.

Once the unfactored moment and shear at the base have been calculated, a factor of safety is applied to each value. It is at this point where LPB's analysis procedure varies from that which is outlined in AASHTO LRFDLTS-1. In the commentary portion of Section 13.6.1.1 (C13.6.1.1), equations are given to determine the required embedment based upon an analysis method developed by Broms (1964a and 1964b). The equations are based upon the ultimate load of the soils and utilize a factored moment and shear at the groundline. The commentary, however, does not clearly state the factor that should be applied to the shear and moment. Previous versions of the AASHTO manual, using an Allowable Stress Design (ASD), show the same procedure for calculating the required embedment depth but clearly state the factors that should be applied to the moment and shear. In AASHTO LTS-6, the commentary references a paper written by Broms where he suggests using an undercapacity factor of 0.7 and an overload factor of 2 to 3. The value for the factor of safety is then determined by dividing the overload factor by the undercapacity factor. Based upon this information, it is LPB's recommendation, that this type of factor of safety should be used when utilizing Broms' approach. The inclusion of this factor can be seen in the analysis process and example calculation.

Step 4B

At this point, the required foundation embedment is determined based upon the soil type and the factored shear and moment. The equations used in the calculation process are shown in the example and follow the method developed by Broms. It is possible that this step may become iterative as additional length is added to the overall foundation or the amount of above grade foundation is reduced to achieve the required embedment. If the required embedment cannot be achieved, based upon the dimensional parameters outlined in Step 1B, then an alternate pole and luminaire configuration may be required.

Step 5B

This step determines the ultimate moment in the foundation shaft for the purposes of checking the reinforcing in the foundation. The equations used for calculating the maximum moment are based upon Broms' approach except that Broms' recommendation for the factor of safety has been removed. Instead, an AASHTO LRFD load factor has been applied. The reason for the difference is that the reinforcing check that is completed in the next step utilizes an LRFD approach and the maximum moment needs to be factored accordingly.

Step 6B

The typical LPB is produced using minimum 5,000 psi concrete and is reinforced with four (4) #6 vertical bars and #3 stirrups spaced at approximately 12-inches on center. Step 6B checks to see if this typical reinforcing is adequate to resist the applied moment in the shaft of the foundation. The check is completed at two locations. The first location is the solid portion of the foundation and the second is at the knockout portion of the foundation where the universal pathway openings are located. In the first location, the entire cross section of concrete is used as well as all four vertical bars. At the second location, the section is treated as a 6-inch wide by 24-inch deep beam with a single #6 bar. LPB has found that in general, the typical reinforcing (noted above) will be adequate and the previous steps in the analysis will generally control in the design.

Design Example

The following Design Example has been prepared to show the analysis process that has been described above. It is important to understand that this example may not depict the Designer's actual site and project conditions. Understanding all of the input parameters and using them accordingly is critical to the analysis process. For additional information or to receive a copy of the analysis tool used to generate this example, please contact LPB.

Anchoring System Analysis

Pole Base Reactions

Are pole base reactions known? (Proceed to Step 1A)

Step 1A - Pole and Luminaire Input Parameters

Pole	Luminaires
Height = <input type="text" value="30"/> ft	EPA Known? <input type="text" value="No"/>
Width/Diameter = <input type="text" value="6.0"/> in	Fixture Contact Area = <input type="text" value="4.00"/> ft ²
Pole Shape <input type="text" value="Round"/>	Luminaire Shape <input type="text" value="Flat Sides"/>

Step 2A - Determine Wind Pressures

Reference: AASHTO LRFD Specifications for Structural Supports for Highway Signs, Luminaires, and Traffic Signals, First Edition as well as applicable portions of ASCE 7-10

$$\text{Wind Pressure} = P_z = 0.00256 \cdot K_z \cdot K_d \cdot G \cdot V^2 \cdot C_d \quad (\text{AASHTO Section 3.8.1})$$

Basic Wind Speed, $V =$ mph (AASHTO Section 3.8.2)
 Wind Exposure Category

$K_z =$ 0.98 (AASHTO Section 3.8.4)

$K_d =$ 0.95 (AASHTO Section 3.8.5)

$G =$ 1.14 (AASHTO Section 3.8.6)

$C_{d \text{ Pole}} =$ 1.00 (AASHTO Section 3.8.7)

$C_{d \text{ Lum}} =$ 1.20 (AASHTO Section 3.8.7)

Pressure on Pole, $P_{z \text{ Pole}} =$ lb/ft²

Pressure on Luminaires, $P_{z \text{ Lum}} =$ lb/ft²

Step 3A - Determine Pole Base Reactions

Pole Area = 15.00 ft²

Luminaire Area = 4.00 ft²

Total Moment at Base, $M_u =$ ft-lb

Total Shear at Base, $V_u =$ lb

(Values shown are calculated based upon the input parameters and include LRFD factors per AASHTO Table 3.4-1. These values will be used in subsequent steps)

Anchoring System Analysis

Step 4A - Determine Tensile Load

Bolt Circle Diameter =	10		
Number of Bolts =	4		
Bolt Diameter =	3/4	in	
Bolt Stress Area =	0.334	in ²	
c =	3.54	in	(Centroid distance to each bolt)
$I_{\text{Bolt Group}}$ =	16.70	in ⁴	(Moment of inertia of bolt group)
Bolt Stress, S_u =	28020	lb/in ²	(Bolt Stress = $M_u \cdot c / I$)
Total Tensile Load, T_u =	9359	lb	

Step 5A - Determine Bolt and Anchoring System Adequacy

Nominal Tensile Capacity, T_n =	18500	lb	(Based upon testing - See App. A)
Strength Reduction Factor, ϕ =	0.70		(ACI 318 - App. D Section D.4.3)

	Applied Load T_u (lb)	Allowable Load ϕT_n (lb)	Result
Adequacy Check	9359	12950	OK

Anchoring System Analysis

Step 6A - Fatigue Analysis - Natural Wind Gust Pressure, Pole Base Reactions and Bolt Stress

Note: Fatigue analysis is based upon input parameters from Steps 2A and 5A. If pole base reactions were manually entered, ensure that the information in Steps 2A and 5A are correct before checking fatigue.

$$\text{Wind Pressure due to Natural Wind Gusts} = P_{NW} = 5.2 \cdot C_d \cdot (V_{\text{mean}}/11.2)^2 \cdot I_F \quad (\text{AASHTO Section 11.7.1.2})$$

$$\begin{aligned} V_{\text{mean}} &= 11.2 \text{ mph} && (\text{Yearly mean wind velocity}) \\ C_{d \text{ Pole}} &= 1.10 && (\text{AASHTO Section 3.8.7}) \\ C_{d \text{ Lum}} &= 1.20 && (\text{AASHTO Section 3.8.7}) \\ \text{Fatigue Category} &= \text{Category III} && (\text{AASHTO Section 11.6}) \\ I_F &= 0.55 && (\text{AASHTO Table 11.6-1}) \end{aligned}$$

$$\begin{aligned} P_{NW \text{ Pole}} &= 3.1 \text{ lb/ft}^2 \\ P_{NW \text{ Lum}} &= 3.4 \text{ lb/ft}^2 \end{aligned}$$

$$\begin{aligned} \text{Pole Area} &= 15.00 \text{ ft}^2 && (\text{From Step 3A}) \\ \text{Luminaire Area} &= 4.00 \text{ ft}^2 && (\text{From Step 3A}) \end{aligned}$$

$$\begin{aligned} \text{Moment, } M_F &= 1120 \text{ ft}\cdot\text{lb} \\ \text{Shear, } V_F &= 61 \text{ lb} \end{aligned}$$

$$\text{Fatigue Bolt Stress, } S_F = 2845 \text{ lb/in}^2 \quad (\text{Similar to calc in Step 5A above using } M_F - \text{ Bolt Stress} = M \cdot c / I)$$

Step 7A - Anchor Bolt Adequacy with Fatigue Loading

	Applied Maximum Stress Range (lb/in ²)	Threshold Stress Range (lb/in ²)	Result
Adequacy Check	2845	7000	OK

	Combined Fatigue and Ultimate Tension $T_F + T_u$ (lb)	Allowable Load ϕT_n (lb)	Result
Additional Check	950 + 9359 = 10309	12950	OK

(Note: The additional check shown above is not prescribed in any Code or industry document. It is ReCon's recommendation that the combined fatigue tension and ultimate design tension remain below the reduced nominal capacity of the anchoring system. This additional check is merely a recommendation and may be used at the Designer's discretion.)

Anchoring System Analysis



References and Tables

Wind Exposure Categories (ASCE 07)

B	Urban and suburban areas, wooded areas, or other terrain with numerous closely spaced obstructions having the size of a single-family dwelling or larger, prevailing for a distance greater than 1500 feet in any direction from the installation
C	Open terrain with scattered obstructions having heights generally less than 30 feet. (Commonly associated with flat open areas and areas not meeting the requirements of Categories B or D)
D	Areas located a close distance (typically within 600 feet) from an "open waterway" one mile or more across. This category is readily distinguishable, where the locally enforced Code very likely has this listed in the requirements.

Height and Exposure Factor, K_z

Exposure Category	α	Z_g
B	7	1200
C	9.5	900
D	11.5	700

From Inputs:

$$\alpha = 9.5$$

$$Z_g = 900$$

Directionality Factor, K_d

Support Type/Pole	Factor
Round	0.95
Square	0.90

Drag Coefficients, C_d (Extreme Limit State $C_v = 0.8$)

Luminaire Shape	Coefficient
Rounded	0.50
Flat Sides	1.20

Pole Shape	Coefficient		
	$C_v Vd \leq 39$ mph-ft	39 mph-ft $< C_v Vd < 78$ mph-ft	$C_v Vd \geq 78$ mph-ft
Round	1.10	$129 / (C_v Vd)^{1.3}$	0.45
		1.00	
Square	$2.0 - 6r_s$ [for $r_s < 0.125$]	1.875	
	1.25 [for $r_s \geq 0.125$]		

Anchoring System Analysis

References and Tables

Drag Coefficients, C_d (Non-Extreme Limit State $C_v = 1.0$)

Luminaire Shape	Coefficient
Rounded	0.50
Flat Sides	1.20

Pole Shape	Coefficient	
Round	$C_v V_d \leq 39 \text{ mph}\cdot\text{ft}$	
	1.10	
Square	2.0 - 6rs [for $r_s < 0.125$]	1.875
	1.25 [for $r_s \geq 0.125$]	

Fatigue Importance Factors, I_f

Fatigue Category	Fatigue Importance Factor
	Natural Wind Gusts
Category I	1.00
Category II	0.80
Category III	0.55

Note: Importance factors shown are from AASHTO Table 11.6-1 for noncantilevered traffic signals.

Notes Regarding Fatigue

According to Chapter 4 of the National Cooperative Highway Research Program (NCHRP) Report 469, anchor rods subject to more than 20,000 repeated applications of significant axial tension shall be checked for the fatigue limit state. The stress range is defined as the magnitude of the change in nominal stress due to the application or removal of the unfactored live load (4.6). The S-N curve for galvanized non-pretensioned anchor rods corresponds to detail Category E', however the fatigue threshold is much greater than other Category E' details. In the case of anchor rods a threshold of 7000 psi should be used (4.6 and C-4.6). No further evaluation of fatigue resistance is required if the stress in the anchor rod remains below the threshold stress range (4.6). Finally, in steel-to-concrete joints subject to fatigue, the anchor rod will fail before the concrete fatigue strength is reached. Therefore, it is not necessary to consider the fatigue strength of the concrete (C-4.6).

Foundation Analysis



Step 1B - Input Foundation Dimensions

Total Foundation Length = 8 ft
 Above Grade Foundation Length = 2.9 ft
 Above Grade Foundation Shape Round
 Above Grade Foundation Diameter = 24 in
 Below Grade Foundation Diameter = 24 in

Step 2B - Input Soil Parameters

Soil Type Cohesionless
 Internal Angle of Friction, ϕ = 30 deg
 Soil Unit Weight, γ = 120 pcf
 Cohesion, c = 0 psf

Step 3B - Determine Ground Line Reactions

Section	Wind Pressure P_z (psf)	Surface Area A (sf)	Force $(P_z \cdot A)$ (lb)	Moment Arm (ft)	Moment (ft · lb)
Foundation	11.8	5.8	68.3	1.45	99.0
Pole	29.9	15.0	448.5	17.9	8028.1
Luminaire	35.8	4.0	143.4	33	4717.8
			660.2		12845.0

Undercapacity Factor = 0.7 (AASHTO (LTS-6) Section C13.6.1.1)
 Overload Factor = 2.0 (AASHTO (LTS-6) Section C13.6.1.1)
 Factor of Safety = 2.9 (Overload/Undercapacity - Broms 1965)

$M_F = 36700.0$ ft · lb (Σ Moment · FoS)
 $V_F = 1886.3$ lb (Σ Force · FoS)

Step 4B - Determine Required Foundation Embedment

Cohesionless Soils (C13.6.1.1-5)

$$L^3 - \frac{2V_F L}{K_p \gamma D} - \frac{2M_F}{K_p \gamma D} = 0$$

$$K_p = \tan^2(45 + \frac{\phi}{2}) \quad K_p = 3.00$$

Cohesive Soils (C13.6.1.1-1)

$$L = 1.5D + q \left(1 + \sqrt{2 + \frac{4H + 6D}{q}} \right)$$

$$H = \frac{M_F}{V_F} \quad H = 19.5 \quad q = \frac{V_F}{9cD} \quad q = na$$

Foundation Analysis

Req'd Embed in Cohesionless Soils, L = 5.0 ft

OK

Step 5B - Determine Ultimate Moment in Foundation Shaft for Reinforcing Check

Max Applied Moment, M_{max} = 12845.0 ft·lb
 Max Applied Shear, V_{max} = 660.2 lb

H = 19.5
 q = na
 K_p = 3.00

Cohesionless Soils (C13.6.1.1-7)

$$M_u = V_{max} \left(H + 0.54 \sqrt{\frac{V_{max}}{\gamma D K_p}} \right)$$

$$Location = 0.82 \sqrt{\frac{V_{max}}{\gamma D K_p}}$$

Max Moment in Shaft, M_u = 13186.4 ft·lb
 Location Below Groundline = 0.79 ft

Cohesive Soils (C13.6.1.1-4)

$$M_u = V_{max} (H + 1.5D + 0.5q)$$

$$Location = 1.5D + q$$

Based upon the equations for Cohesionless soils

Step 6B - Check Reinforcing in Foundation Shaft

Concrete Strength, f'_c = 5000 psi
 Reinforcing Yield Strength, f_y = 60000 psi
 Concrete Unit Weight = 145 pcf
 Reduction Factor, ϕ = 0.9

Bar Cover = 3 in
 Bar Size = 6
 Number of Bars = 4
 Stirrup Size = 3

Check Within the Soild Portion of the Foundation Shaft:

Gross Area of Total Section, A_g = 452.4 in²
 Dist between Bar Centers, z = 16.5 in
 Area Steel Provided, A_{sg} = 1.77 in²

$$\rho_{req} = \left[1 - \left(\sqrt{1 - \frac{2 \cdot M_u}{\phi \cdot A_g \cdot z \cdot 0.85 f'_c}} \right) \right] \cdot \frac{0.85 f'_c}{f_y} \geq 0.0033$$

ρ_{req} = 0.00330

$\rho_{prov} = A_{sg} / A_g = 0.00391$

OK

Foundation Analysis

Step 6B - Check Reinforcing in Foundation Shaft (Continued)

Check Within the Knockout Portion of the Foundation Shaft - Treat as 24" Deep by 6" Wide Beam:

Beam Width, b =	6	in
Dist Outer Edge to Bar Center, d =	20.3	in
Beam Area (b·d), A _b =	121.5	in ²
Area Steel Provided, A _{sb} =	0.44	in ²

$$\rho_{req} = \left[1 - \left(\sqrt{1 - \frac{2 \cdot M_u}{\phi \cdot b d^2 \cdot 0.85 f'_c}} \right) \right] \cdot \frac{0.85 f'_c}{f_y} \geq 0.0033$$

$$\rho_{req} = 0.00330$$

$$\rho_{prov} = A_{sb} / A_b = 0.00364 \quad \text{OK}$$

Design Tables

Overview and Notes

The LPB Design Tables have been prepared to demonstrate the capabilities of the foundation system with a variety of pole and fixture size scenarios. They have been prepared using a number of assumptions that can be found on each individual table. It is important to read and understand all of these assumptions. The tables have been prepared by ReCon Wall Systems, Inc. and to the best of ReCon's knowledge accurately represent the product use in the intended application. Anyone making use of these tables does so at their own risk and assumes all liability for such use. Final design, for construction purposes, must be completed by a Professional Engineer who is familiar with the project and has considered the specific site conditions.

The tables have been prepared in general accordance, as described in the Design Approach section of this manual, with the requirements found in the American Association of State Highway and Transportation Officials (AASHTO) publications: LRFD Specifications for Structural Supports for Highway Signs, Luminaires, and Traffic Signals, First Edition, 2015 (LRFDLTS-1)

Tables Included:

- 105 mph, Exposure C
 - 4-inch, 6-inch, and 8-inch Round Poles, 4-inch and 6-inch Square Poles
- 120 mph, Exposure C
 - 4-inch, 6-inch, and 8-inch Round Poles, 4-inch and 6-inch Square Poles
- 130 mph, Exposure C
 - 4-inch, 6-inch, and 8-inch Round Poles, 4-inch and 6-inch Square Poles

General:

- The LPB is produced with an embedded anchoring system that consists of four slots, created by plastic inserts, each containing an anchoring nut that is located approximately 4-½-inches below the top concrete surface. Each anchoring nut receives one (1) ¾-inch diameter threaded anchor rod that projects from the top of the foundation. The anchor rod is secured in place using a single nut and a 3-inch by 3-inch bearing washer. The capacity of the anchoring system was determined through load testing completed by Braun Intertec. Refer to Appendix A for additional information regarding the testing completed.
- For the purposes of the Design Tables, the LPB is assumed to be round, 24-inches in diameter, with a total height of 8-feet (maximum of 3-feet exposed above grade). A 6-foot foundation may be used in lieu of the 8-foot foundation shown in the tables provided the minimum bury depth does not exceed 6-feet.
- For round-tapered and square-tapered light poles, the average diameter or width should be used to determine minimum bolt circle diameter and embedment depth within the tables.
- The tables assume a double light fixture with a total wind surface area equal to that shown. Single light fixtures, creating an unbalanced load condition, are not covered within the Design Tables.
- The weight of the fixtures, pole, and foundation are neglected as resisting forces in the calculation process.

How to use the LPB Design Tables

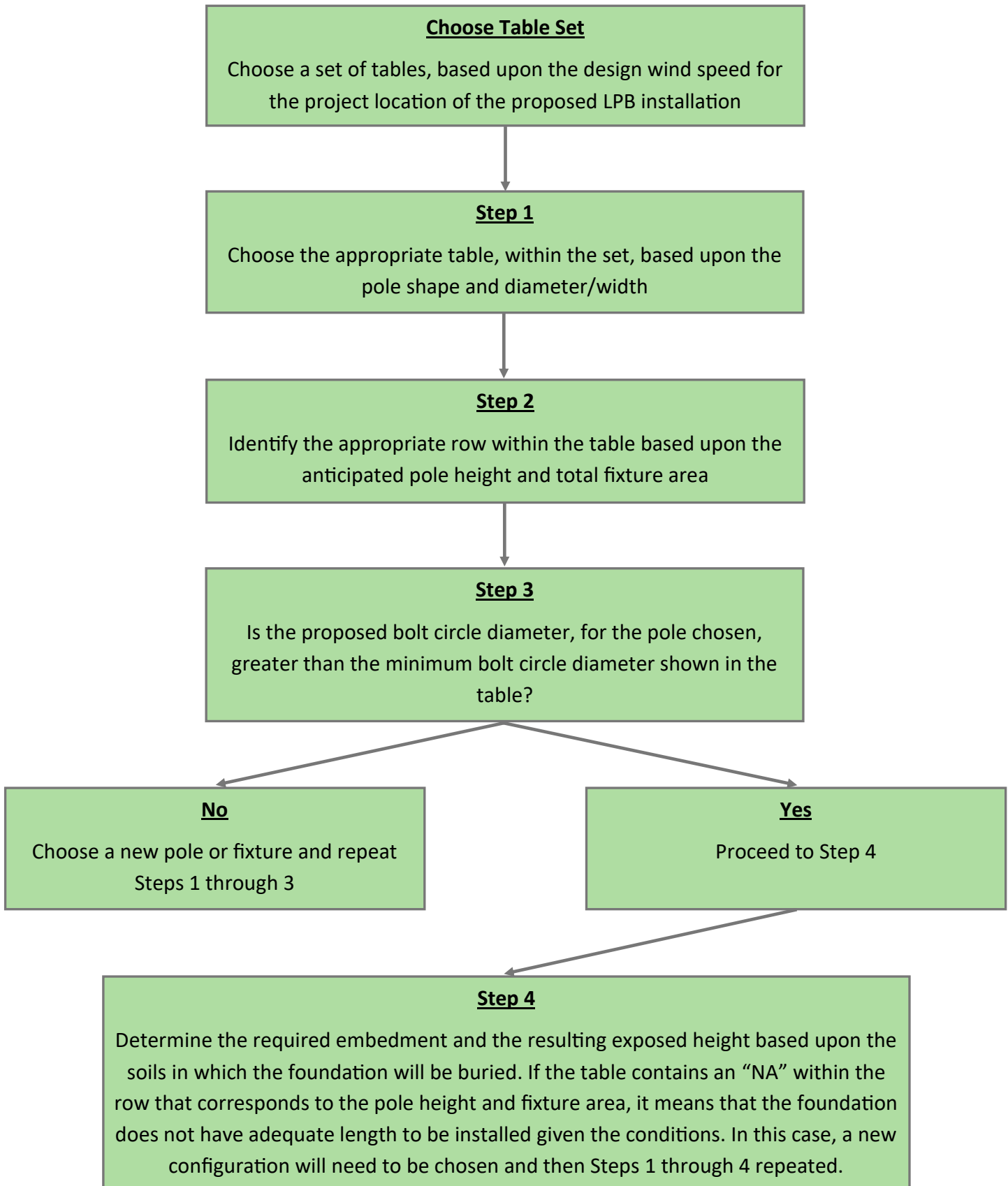

LPB Design Tables - 105 mph, Exposure C



Determining Minimum Bolt Circle Diameter and Embedment (8-foot LPB with 3-feet Exposed)

Step 1

Pole Size: 4-inch Diameter	Pole Shape: Round
-----------------------------------	--------------------------

Step 4

Step 2

Pole Height (ft)	Fixture Area (ft ²)
15	1.0
	2.0
	4.0
	6.0
20	1.0
	2.0
	4.0
	6.0
25	1.0
	2.0
	4.0
	6.0
30	1.0
	2.0
	4.0
	6.0

Step 3

Minimum Bolt Circle Diameter (in)
7.5
7.5
7.5
7.5
7.5
7.5
7.5
7.5
7.5
7.5
7.5
7.5
7.5
7.5
7.5
7.5
9.0

Cohesionless Soils $\phi = 30^\circ$ and $c = 0$ psf		Cohesive Soils $\phi = 12^\circ$ and $c = 250$ psf	
Minimum Bury Depth (ft)	Resulting Exposed Height (ft)	Minimum Bury Depth (ft)	Resulting Exposed Height (ft)
5.0	3.0	5.8	2.2
5.0	3.0	6.1	1.9
5.0	3.0	6.5	1.5
5.0	3.0	7.0	1.0
5.0	3.0	6.4	1.6
5.0	3.0	6.7	1.3
5.0	3.0	7.2	0.8
5.0	3.0	7.6	0.4
5.0	3.0	7.0	1.0
5.0	3.0	7.4	0.6
5.0	3.0	8.0	0.0
5.0	3.0	NA	
5.0	3.0	7.6	0.4
5.0	3.0	8.0	0.0
5.0	3.0	NA	
5.1	2.9	NA	

General Notes:

- A 6-foot (total height) LPB may be used in lieu of the 8-foot LPB provided that the minimum bury depth is less than 6-feet. The resulting exposed height would then need to be adjusted accordingly.
- LPB size: round, 24" diameter
- For round-tapered and square-tapers poles, use average diameter or width.
- Table assumes double light fixture with total fixture as shown. Single light fixtures creating an unbalanced load condition are not covered by this table.
- Weight of fixtures, pole, and foundation are neglected as resisting forces.

Wind Loading Assumptions:

- Load Combinations and Load Factors: per AASHTO Section 3.4 and Table 3.4-1. For Extreme II the Load Factor for wind is 1.0.
- The basic wind speed V : per AASHTO Section 3.8.2. $V = 105$ mph; Risk Category: Low; Mean Recurrence Interval: 300 Years
- Wind Exposure Category: C
- Height and Exposure Factor K_z : per AASHTO Section 3.8.4. For poles and fixtures this value is calculated for Exposure C and the actual height of the pole. For the pole foundation, $K_z = 0.86$.
- Directionality Factor K_d : per AASHTO Section 3.8.5. $K_d = 0.95$ for round poles.
- Gust Effect Factor G : per AASHTO Section 3.8.6. $G = 1.14$

Wind Loading Assumptions Cont.:

- Drag Coefficients C_d : per AASHTO Section 3.8.7
 $C_d = 0.8$ for Extreme Limit Case
 Light Fixture, $C_d = 1.2$ (flat side shapes)
 Round Light Poles, $C_d = 1.10$ (4-inch dia)

Fatigue Analysis Assumptions (for bolt circle diameter only):

- Yearly Mean Wind Velocity V_{mean} : per AASHTO Section C11.7.1.2. $V_{mean} = 11.2$ miles per hour
- Drag Coefficients C_d : per AASHTO Section 3.8.7
 $C_d = 1.0$ for Non-Extreme Limit Case
 Light Fixture, $C_d = 1.2$ (flat side shapes)
 Round Light Poles, $C_d = 1.10$
- Fatigue Importance Factor I_f : per AASHTO Section 11.6 and Table 11.6-1. $I_f = 0.55$ for noncantilevered traffic signals; Category III
- Fatigue loading check per AASHTO LRFDLTS-1 and NCHRP Report 496. Refer to the Design approach section of this report for additional information.

Foundation Analysis Assumptions:

- Foundation analysis per AASHTO Section 13.6.1.1
- Minimum Bury in Cohesionless Soils per AASHTO Equation C13.6.1.1-5
- Minimum Bury in Cohesive Soils per AASHTO Equation C13.6.1.1-1
- Overload Factor = 2.0 per AASHTO (LTS-6) Section C13.6.1.1
- Under Capacity Factor = 0.7 per AASHTO (LTS-6) Section C13.6.1.1

LPB Design Tables - 105 mph, Exposure C



Determining Minimum Bolt Circle Diameter and Embedment (8-foot LPB with 3-feet Exposed)

Step 1

Pole Size: 6-inch Width	Pole Shape: Square
--------------------------------	---------------------------

Step 4

Step 2

Pole Height (ft)	Fixture Area (ft ²)
15	1.0
	2.0
	4.0
	6.0
20	1.0
	2.0
	4.0
	6.0
25	1.0
	2.0
	4.0
	6.0
30	1.0
	2.0
	4.0
	6.0

Step 3

Minimum Bolt Circle Diameter (in)
7.5
7.5
7.5
7.5
7.5
7.5
7.5
7.5
7.5
7.5
7.5
8.0
9.5
10.5
9.5
11.0
13.0
NA

Cohesionless Soils $\phi = 30^\circ$ and $c = 0$ psf		Cohesive Soils $\phi = 12^\circ$ and $c = 250$ psf	
Minimum Bury Depth (ft)	Resulting Exposed Height (ft)	Minimum Bury Depth (ft)	Resulting Exposed Height (ft)
5.0	3.0	6.8	1.2
5.0	3.0	7.0	1.0
5.0	3.0	7.3	0.7
5.0	3.0	7.6	0.4
5.0	3.0	7.7	0.3
5.0	3.0	7.9	0.1
5.0	3.0	NA	
5.0	3.0	NA	
5.0	3.0	NA	
5.0	3.0	NA	
5.3	2.7	NA	
5.5	2.5	NA	
5.5	2.5	NA	
5.6	2.4	NA	
5.8	2.2	NA	
NA		NA	

General Notes:

- A 6-foot (total height) LPB may be used in lieu of the 8-foot LPB provided that the minimum bury depth is less than 6-feet. The resulting exposed height would then need to be adjusted accordingly.
- LPB size: round, 24" diameter
- For round-tapered and square-tapers poles, use average diameter or width.
- Table assumes double light fixture with total fixture as shown. Single light fixtures creating an unbalanced load condition are not covered by this table.
- Weight of fixtures, pole, and foundation are neglected as resisting forces.

Wind Loading Assumptions:

- Load Combinations and Load Factors: per AASHTO Section 3.4 and Table 3.4-1. For Extreme II the Load Factor for wind is 1.0.
- The basic wind speed V : per AASHTO Section 3.8.2. $V = 105$ mph; Risk Category: Low; Mean Recurrence Interval: 300 Years
- Wind Exposure Category: C
- Height and Exposure Factor K_z : per AASHTO Section 3.8.4. For poles and fixtures this value is calculated for Exposure C and the actual height of the pole. For the pole foundation, $K_z = 0.86$.
- Directionality Factor K_d : per AASHTO Section 3.8.5. $K_d = 0.90$ for square poles.
- Gust Effect Factor G : per AASHTO Section 3.8.6. $G = 1.14$

Wind Loading Assumptions Cont.:

- Drag Coefficients C_d : per AASHTO Section 3.8.7
 $C_d = 0.8$ for Extreme Limit Case
 Light Fixture, $C_d = 1.2$ (flat side shapes)
 Square Light Poles, $C_d = 1.875$ (6-inch wide)

Fatigue Analysis Assumptions (for bolt circle diameter only):

- Yearly Mean Wind Velocity V_{mean} : per AASHTO Section C11.7.1.2. $V_{mean} = 11.2$ miles per hour
- Drag Coefficients C_d : per AASHTO Section 3.8.7
 $C_d = 1.0$ for Non-Extreme Limit Case
 Light Fixture, $C_d = 1.2$ (flat side shapes)
 Square Light Poles, $C_d = 1.875$ (6-inch wide)
- Fatigue Importance Factor I_f : per AASHTO Section 11.6 and Table 11.6-1. $I_f = 0.55$ for noncantilevered traffic signals; Category III
- Fatigue loading check per AASHTO LRFDLTS-1 and NCHRP Report 496. Refer to the Design approach section of this report for additional information.

Foundation Analysis Assumptions:

- Foundation analysis per AASHTO Section 13.6.1.1
- Minimum Bury in Cohesionless Soils per AASHTO Equation C13.6.1.1-5
- Minimum Bury in Cohesive Soils per AASHTO Equation C13.6.1.1-1
- Overload Factor = 2.0 per AASHTO (LTS-6) Section C13.6.1.1
- Under Capacity Factor = 0.7 per AASHTO (LTS-6) Section C13.6.1.1

Determining Minimum Bolt Circle Diameter and Embedment (8-foot LPB with 3-feet Exposed)

Step 1

Pole Size: 4-inch Width	Pole Shape: Square
--------------------------------	---------------------------

Step 4

Step 2

Pole Height (ft)	Fixture Area (ft ²)
15	1.0
	2.0
	4.0
	6.0
20	1.0
	2.0
	4.0
	6.0
25	1.0
	2.0
	4.0
	6.0
30	1.0
	2.0
	4.0
	6.0

Step 3

Minimum Bolt Circle Diameter (in)
7.5
7.5
7.5
7.5
7.5
7.5
7.5
7.5
7.5
7.5
9.5
9.5
10.5
13.0
NA

Cohesionless Soils $\phi = 30^\circ$ and $c = 0$ psf		Cohesive Soils $\phi = 12^\circ$ and $c = 250$ psf	
Minimum Bury Depth (ft)	Resulting Exposed Height (ft)	Minimum Bury Depth (ft)	Resulting Exposed Height (ft)
5.0	3.0	6.9	1.1
5.0	3.0	7.2	0.8
5.0	3.0	7.7	0.3
5.0	3.0	NA	
5.0	3.0	7.8	0.2
5.0	3.0	NA	
5.0	3.0	NA	
5.2	2.8	NA	
5.0	3.0	NA	
5.2	2.8	NA	
5.5	2.5	NA	
5.8	2.2	NA	
5.5	2.5	NA	
5.7	2.3	NA	
6.0	2.0	NA	
NA		NA	

General Notes:

- A 6-foot (total height) LPB may be used in lieu of the 8-foot LPB provided that the minimum bury depth is less than 6-feet. The resulting exposed height would then need to be adjusted accordingly.
- LPB size: round, 24" diameter
- For round-tapered and square-tapers poles, use average diameter or width.
- Table assumes double light fixture with total fixture as shown. Single light fixtures creating an unbalanced load condition are not covered by this table.
- Weight of fixtures, pole, and foundation are neglected as resisting forces.

Wind Loading Assumptions:

- Load Combinations and Load Factors: per AASHTO Section 3.4 and Table 3.4-1. For Extreme II the Load Factor for wind is 1.0.
- The basic wind speed V : per AASHTO Section 3.8.2. $V = 130$ mph; Risk Category: Low; Mean Recurrence Interval: 300 Years
- Wind Exposure Category: C
- Height and Exposure Factor K_z : per AASHTO Section 3.8.4. For poles and fixtures this value is calculated for Exposure C and the actual height of the pole. For the pole foundation, $K_z = 0.86$.
- Directionality Factor K_d : per AASHTO Section 3.8.5. $K_d = 0.90$ for square poles.
- Gust Effect Factor G : per AASHTO Section 3.8.6. $G = 1.14$

Wind Loading Assumptions Cont.:

- Drag Coefficients C_d : per AASHTO Section 3.8.7
 $C_d = 0.8$ for Extreme Limit Case
 Light Fixture, $C_d = 1.2$ (flat side shapes)
 Square Light Poles, $C_d = 1.81$ (4-inch wide)

Fatigue Analysis Assumptions (for bolt circle diameter only):

- Yearly Mean Wind Velocity V_{mean} : per AASHTO Section C11.7.1.2. $V_{mean} = 11.2$ miles per hour
- Drag Coefficients C_d : per AASHTO Section 3.8.7
 $C_d = 1.0$ for Non-Extreme Limit Case
 Light Fixture, $C_d = 1.2$ (flat side shapes)
 Square Light Poles, $C_d = 1.81$ (4-inch wide)
- Fatigue Importance Factor I_f : per AASHTO Section 11.6 and Table 11.6-1. $I_f = 0.55$ for noncantilevered traffic signals; Category III
- Fatigue loading check per AASHTO LRFDLTS-1 and NCHRP Report 496. Refer to the Design approach section of this report for additional information.

Foundation Analysis Assumptions:

- Foundation analysis per AASHTO Section 13.6.1.1
- Minimum Bury in Cohesionless Soils per AASHTO Equation C13.6.1.1-5
- Minimum Bury in Cohesive Soils per AASHTO Equation C13.6.1.1-1
- Overload Factor = 2.0 per AASHTO (LTS-6) Section C13.6.1.1
- Under Capacity Factor = 0.7 per AASHTO (LTS-6) Section C13.6.1.1

Product Drawings

SPECIFICATION SUMMARY - LPB

- CONCRETE: MINIMUM 5,000 PSI AT 28 DAYS / AIR ENTRAINED
- LENGTH: 4' TO 8' (IN 1' INCREMENTS)
- DIAMETER: 24"
- ANCHORING SYSTEM: 7 1/2" TO 13 1/2" BOLT CIRCLE DIAMETERS
- SIDE OPENINGS FOR CONDUIT INSTALLATION: 4

BILL OF MATERIALS SUMMARY - PRODUCTION

- ① (4) INSERTS WITH ANCHORING NUT
- ② (8) U-BARS CONNECTED TO INSERTS - ASTM A615 GRADE 60
- ③ (4) #6 REBAR - ASTM A615 GRADE 60
- ④ (*) #3 REBAR HOOPS (18" Ø) - ASTM A615 GRADE 60 (* QUANTITY BASED UPON TOTAL HEIGHT)
- ⑤ 4" Ø PVC PIPE - ASTM D2729 (LENGTH BASED UPON TOTAL HEIGHT)
- ⑥ (4) UTILITY LIFTING ANCHOR

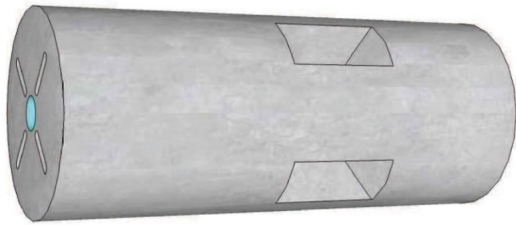

LPB
ISOMETRIC VIEW

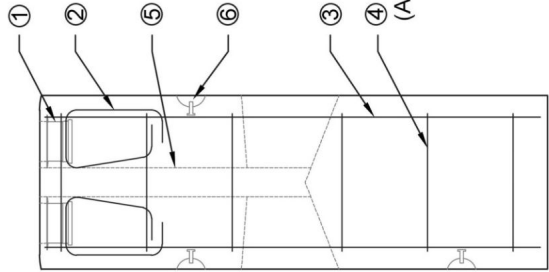

LPB
PRODUCTION LAYOUT

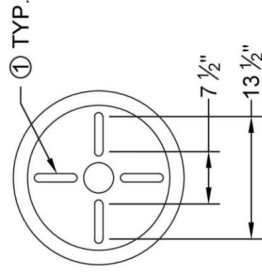

LPB
ANCHORING SYSTEM

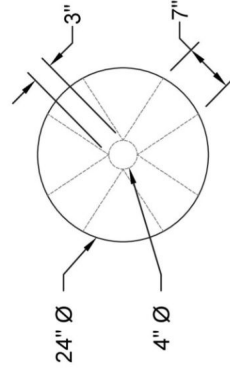

LPB
SIDE OPENINGS AND CENTRAL PATHWAY

(APPROX. 12" O.C.)

© Copyright 2019 ReCon Wall Systems, Inc. All Rights Reserved

Disclaimer: This drawing has been prepared by ReCon Wall Systems, Inc. and to the best of its knowledge, accurately represents the product use in the application that it is illustrated. This drawing is intended for conceptual purposes only. Anyone making use of this drawing does so at their own risk and assumes all liability for such use. Final design for construction purposes must be completed by a Registered Professional Engineer who is familiar with the product and who has taken into account specific site conditions.



DRAWING #5001

LPB
TYPICAL LAYOUT

RECON WALL SYSTEMS, INC.
7600 W. 27th STREET, #229
ST. LOUIS PARK, MN 55426
952-922-0027
www.lightpolebase.com

BILL OF MATERIALS SUMMARY - LPB INSTALLATION HARDWARE

- ① (4) 3/4" Ø x 9" LONG HDG THREADED RODS - ASTM F1554 GRADE 55
- ② (4) 3/4" HEAVY HEX HDG NUT - ASTM A563 GRADE DH
- ③ (4) 3" x 3" x 5/16" THICK HDG BEARING PLATE - ASTM A36

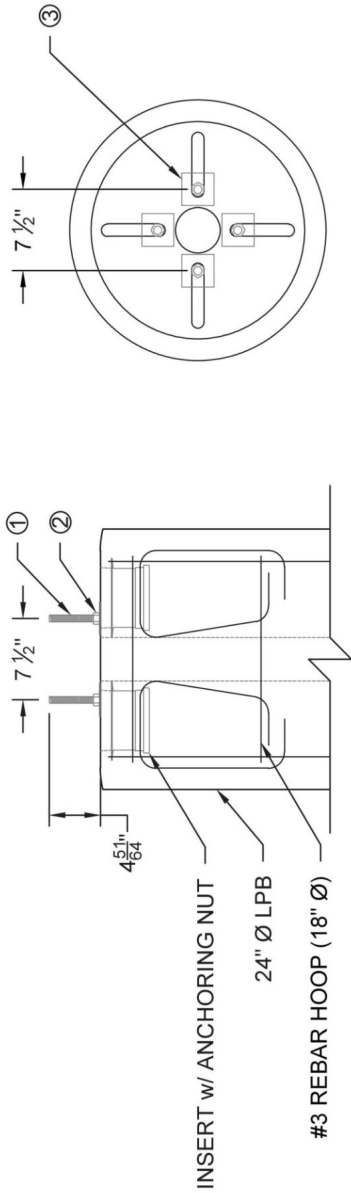

NOTE:
ALL NOTES APPLY EQUALLY EXCEPT FOR BOLT CIRCLE DIAMETER

LPB ANCHORING SYSTEM
7 1/2" BOLT CIRCLE DIAMETER

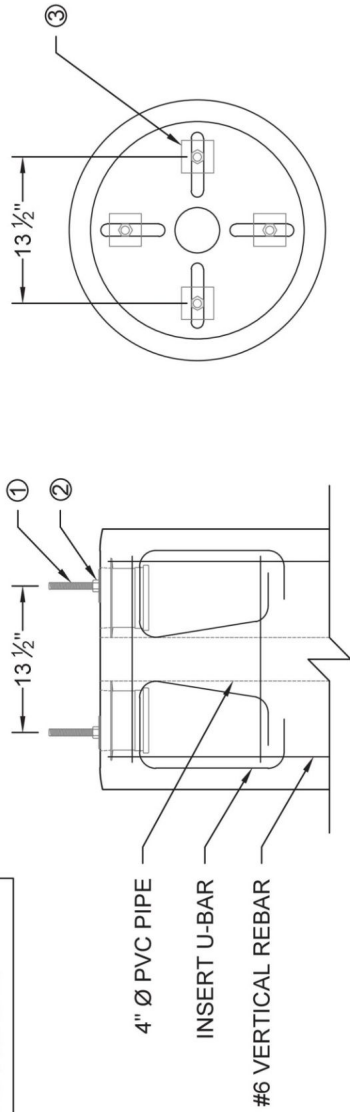

LPB ANCHORING SYSTEM
13 1/2" BOLT CIRCLE DIAMETER

© Copyright 2019 ReCon Wall Systems, Inc. All Rights Reserved

Disclaimer: This drawing has been prepared by ReCon Wall Systems, Inc. and to the best of its knowledge, accurately represents the product use in the application that it is illustrated. This drawing is intended for conceptual purposes only. Anyone making use of this drawing does so at their own risk and assumes all liability for such use. Final design for construction purposes must be completed by a Registered Professional Engineer who is familiar with the product and who has taken into account specific site conditions.



DRAWING #5002

LPB ANCHORING SYSTEM

RECON WALL SYSTEMS, INC.
7600 W. 27th STREET, #229
ST. LOUIS PARK, MN 55426
952-922-0027
www.lightpolebase.com

Appendix A

January 8, 2018

Project B1711078

ReCon Wall Systems, Inc.
7600 West 27th St. #229
St. Louis Park, MN 55426

Re: Universal Precast Light Pole Foundation Testing

This report is a summary of load testing performed on ReCon light pole foundations. The purpose of the testing was to verify the anchorage could withstand a test load of 18,500 lbf.

Test Samples

Four concrete samples were cast using forms provided by ReCon Wall Systems, Inc. Each of the samples was 24" in diameter and 18" in depth with a vertical 4" penetration at the center. The foundation contained 4 Dayton Superior anchors tied into the foundation using two #4 bar per anchor. Each anchor contains a single $\frac{3}{4}$ " threaded tee nut to accept threaded rod. All reinforcing steel was ASTM A615 grade 60. Figure 1 below Shows the reinforcing and anchor layouts.

Figure 1: Reinforcing Layout

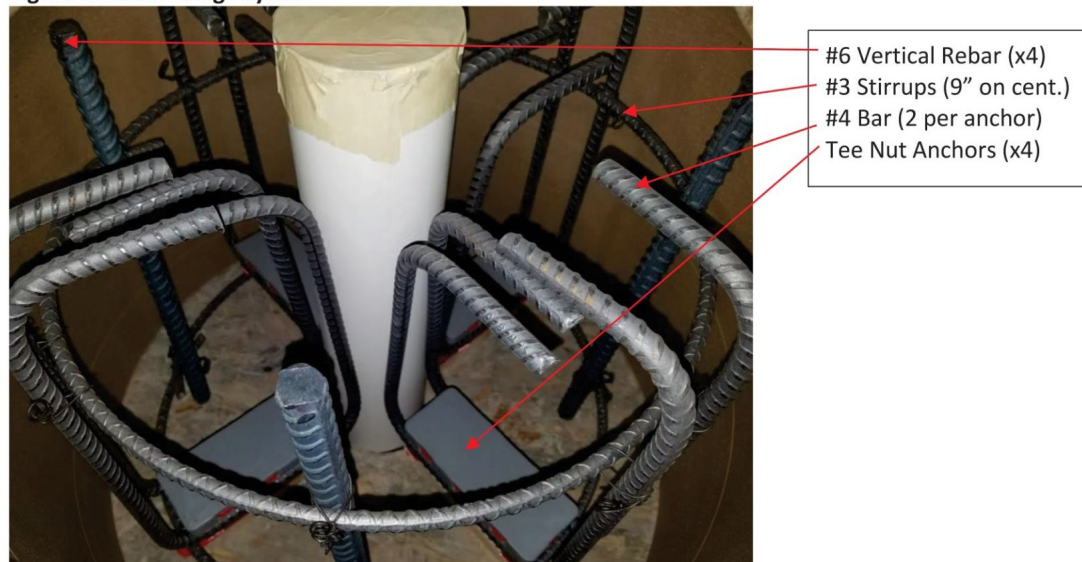

AA/EOE

Concrete Mix Design and Strength Verification

The concrete mixture used for this project was selected based on its ability to reach approximately 5,000 psi within 7 days of age. Upon delivery, an ASTM C494, Type A water reducing admixture was added to the mixture to produce a 5 inch slump. The mixture was produced with the following components shown in Table 1.

Table 1: Concrete Mix Design

Material	Quantity
Cement – ASTM C150 Type I	470 lb./yd ³
Faulkstone 3/4"- Gravel	1550 lb./yd ³
UMore Sand	1630 lb./yd ³
Water	259 lb./yd ³
ASTM C260 Air Entraining Admixture	3.6 oz./yd ³

In addition to the light pole foundation samples, compressive strength cylinders were also cast. Cylinders were cast, cured, and tested in accordance with ASTM C192, "Standard Practice for Making and Curing Concrete Test Specimens in the Laboratory" and ASTM C39, "Standard Test Method for Compressive Strength of Cylindrical Concrete Specimens". After 3 days of curing compressive strength cylinders were tested daily until the desired strength was reached. A set of 3 cylinders was broken on the day of the foundation testing and the results are shown in Table 2 below and attached to this report.

Table 2: Concrete Compressive Strength Results

Cylinder Specimen Age (days)	Compressive Strength (psi)	Average Compressive Strength (psi)
7	4,600	4,680
7	4,640	
7	4,800	

Load Test Procedure

Two to four anchors in each foundation were load tested in tension. The samples were restrained by placing them in a load frame with two I-Beams bearing on the top face. The load was applied to a single Dayton Superior 3/4"-16 tee nut inserted into the channel using a calibrated hydraulic ram. The general test setup is shown in figure 3 below.

Figure 3: Test Setup

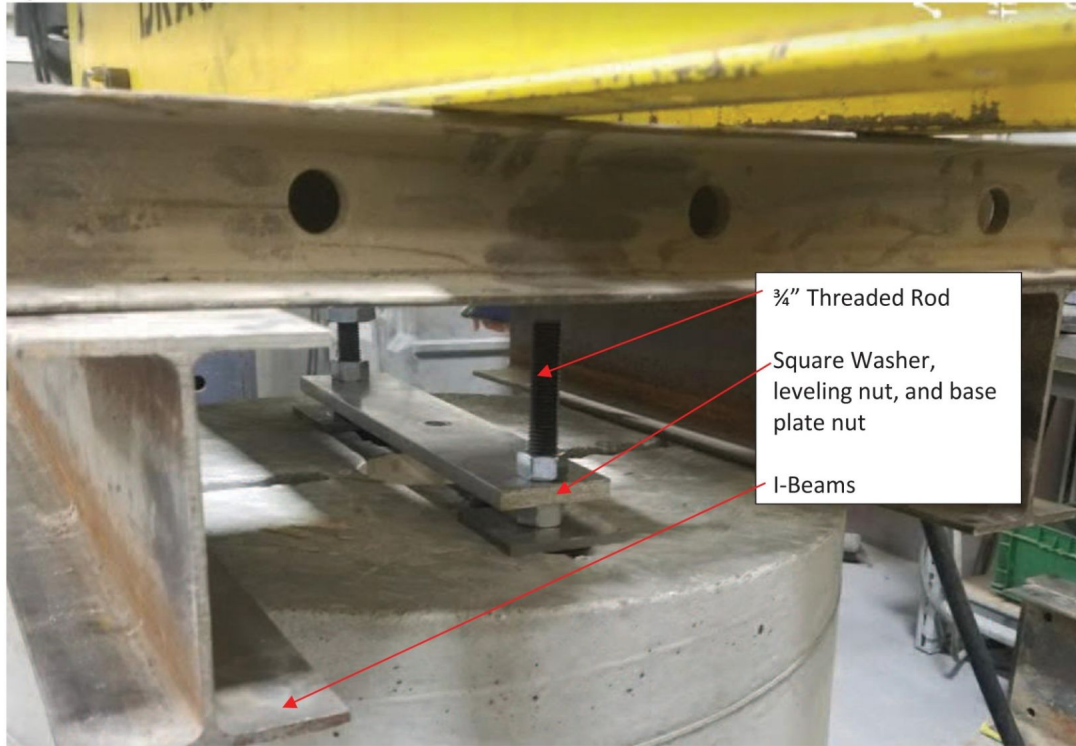

Load tests were performed with the threaded rod located either 3 3/4", 5", or 7" from the center of the foundation. These locations were selected to cover the full range of bolt circle diameters allowed by ReCon Wall Systems, Inc. A test load of 18,500 lbf was applied during each test and any visible cracks that appeared prior to that load were noted.

Test Results.

The test results are shown in table 3 below.

Table 3: Load Test Results

7.5" Bolt Spacing				
Test Number	Foundation Number	Load Applied (lbf)	Load at First Crack (lbf)	Test Result
1	1	18,500	NA	Pass
2	1	18,500	NA	Pass
3	2	18,500	NA	Pass
4	2	18,500	NA	Pass
10" Bolt Spacing				
Test Number	Foundation Number	Load Applied (lbf)	Load at First Crack (lbf)	Test Result
1	3	18,500	NA	Pass
2	3	18,500	17,900	Pass
3	4	18,500	NA	Pass
4	4	18,500	17,550	Pass
14" Bolt Spacing				
Test Number	Foundation Number	Load Applied (lbf)	Load at First Crack (lbf)	Test Result
1	1	18,500	16,900	Pass
2	2	18,500	NA	Pass
3	2	18,500	16,250	Pass
4	3	18,500	17,500	Pass

All of the cracks occurring prior to reaching the test load appeared in a typical fashion. A vertical crack would start at the outside of the anchor and extend to the edge of the foundation and down the outside



face to the approximate elevation of the first stirrup. The crack would then extend radially at around the circumference of the sample. An example of the cracks noted is shown in figure 4 below.

Figure 4: Typical Cracking Pattern



General

In performing its services, Braun Intertec used that degree of care and skill ordinarily exercised under similar circumstances by reputable members of its profession currently practicing in the same locality. No warranty, express or implied, is made.

It has been a pleasure providing these testing services for you. If you have any questions regarding this report, please call Erik Knudson at 952.995.2384.

Sincerely,

BRAUN INTERTEC CORPORATION

Erik J. Knudson
Material Testing Technician

Attachments:
Concrete Compressive Strength Report

BRAUN
INTERTEC

11001 Hampshire Avenue S
Minneapolis, MN 55438
Phone: 952-995-2000

Client:
ReCon Wall Systems, Inc
7600 West 27th St., #229
St Louis Park, MN 55426

Project:
B1711078
Light Pole Foundation Testing
Bloomington Lab
Bloomington, MN 55438

Sample Details		
Set #:	1	Technician: Kauffman, Jayson
Specimen Size:	4" X 8"	Cast By: Kauffman, Jayson
Specimens In Set:	3	Date Cast: 12/08/17
Truck / Ticket #:		Sampled From: Chute
Contractor:		Placement Method:
		Batched:
		Sampled: 13:15 CST
		Cast: 13:25 CST
		Truck Empty:
		Placement Time:
Location		
Placement Location:	Lab Cast	
Location Details:	Lab Cast Cylinders	
Sample Location / Notes:	Lab Cast	
Batch Log		Specifications
On-Site Admixtures: None		Strength: 5000 (psi)
Field Measurements		
Weather:	Slump (in): 5-3/4 (ASTM C143)	Plastic Unit Weight:
Air Temperature (F):	Concrete Temp (F):	Air Content: 5.1 (ASTM C231)
		Load Volume:
Standard Cure		Field Cure

Lab Test Results										
Testing Lab: Bloomington, 11001 Hampshire Ave S, Bloomington, MN, 55438										
Specimen Number	Test Age Days	Test Date	Field / Lab Cure Days	Average Cylinder Diameter (in)	Cylinder Area (in ²)	Max Load (lbs)	Strength (psi)	Fracture Type	Break Remark	Capping Method
1-1	7	12/15/17	7 / 0	4.00	12.57	57,820	4,600	5	1A	N
1-2	7	12/15/17	7 / 0	4.00	12.57	58,320	4,640	5	1A	N
1-3	7	12/15/17	7 / 0	4.00	12.57	60,340	4,800	5	1A	N
Test Age Average Strengths (psi): 7 Day - 4680										
Break Remarks								Capping Methods		
1A: The test result is for informational purposes.								N: ASTM C1231, Unbonded Caps		

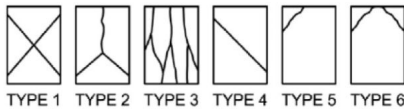

Kauffman, Jayson

Signed on Behalf of Erik Knudson

Appendix B

January 22, 2018

Project B1709706

Michael Klotthor, PE
ReCon Wall Systems, Inc.
7600 West 27th St., #229
St. Louis Park, MN 55426

Re: Peer Review
ReCon UniBase

Dear Mr. Klotthor:

This letter is to document our involvement completing a peer review of the proposed ReCon UniBase.

Background

ReCon Wall Systems, Inc. (ReCon) has developed a prefabricated, pole base system. The prefabricated foundation element consists of formed-cast concrete piers with embedded anchor locations. The prefabricated pier is then placed at a designated location and the new pole can then be attached to the pier using the embedded anchor points. The precast ReCon UniBase system is designed to accept a determined and specified range of pole heights with specified size range of attached luminaries to the pole.

ReCon has prepared calculations and a narrative description of the design process of the ReCon UniBase system that will be published as part of their product literature. Braun Intertec Corporation has been retained to complete an independent-party peer review of the documents and calculations.

Scope of Work

The following comprised Braun Intertec's scope of work:

- Review of documents provided by ReCon that include the narrative description of the design process and the calculations completed for the design. Edits and comments were provided accordingly and the calculations were reviewed for general accordance with standard practices and comment and questioned as needed. We did not complete separate or independent calculations as part of this review.
- Upon review and general agreement with the process, and correction of any items noted upon completion of the review, a statement letter that acknowledges that we (Braun Intertec) have reviewed the documents and calculations and are in general agreement with the process and calculations performed, will be provided.

AA/EOE

Discussion

As of January 17, 2018, Braun Intertec has reviewed material provided that includes the following:

- ReCon Unibase Design Approach Document
- ReCon UniBase Design Tables
- ReCon UniBase Calculations Excel Spreadsheet File
- Foundation Test with Dayton Inserts Report performed by Braun Intertec and dated January 8, 2018 (Project Number B1711078)

Based on our review and comments and responses received, we are in general agreement with the process and analysis performed for the design of the ReCon UniBase System. It is our opinion that the test method used for the "Foundation Test with Dayton Inserts" was an appropriate test method for the anticipated use of the light pole base. It is also our opinion that given the results of the testing, the nominal capacity of the anchors embedded in the concrete base determined by ReCon is appropriate.

General

In performing its services, Braun Intertec used that degree of care and skill ordinarily exercised under similar circumstances by reputable members of its profession currently practicing in the same locality. No warranty, express or implied, is made.

If you have any questions, please contact me.

Sincerely,

BRAUN INTERTEC CORPORATION



Jason S. Hanlon, PE, MLSE
Associate Principal – Principal Structural Engineer
Minnesota License No. 41941

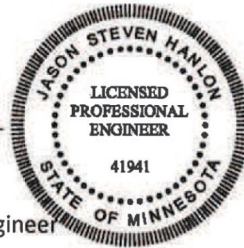

Reviewer:



Alfred J. Gardiner
Principal

BRAUN
INTERTEC

References

AASHTO. 2015. *LRFD Specifications for Structural Supports for Highway Signs, Luminaires, and Traffic Signals*, First Edition, LRFDLTS-1. American Association of State Highway and Transportation Officials, Washington, DC.

AASHTO. 2013. *Specifications for Structural Supports for Highway Signs, Luminaires, and Traffic Signals*, First Edition, LTS-6. American Association of State Highway and Transportation Officials, Washington, DC.

ASCE. 2010. *Minimum Design Loads for Buildings and Other Structures*, Report no. ASCE/SEI 7-10. American Society of Civil Engineers, VA.

ACI. 2011. *Building Code Requirements for Structural Concrete*, ACI 318-11. American Concrete Institute, Farmington Hills, MI.

Dexter, R., and M. Ricker. 2002. *Fatigue-Resistant Design of Cantilever Signal, Sign, and Light Supports*, NCHRP Report 469. Transportation Research Board, National Research Council, Washington, DC.

Kaczinski, M. R., R. J. Dexter, and J. P. Van Dien. 1998. *Fatigue Resistant Design of Cantilever Signal, Sign, and Light Supports*, NCHRP Report 412. Transportation Research Board, National Research Council, Washington, DC.

Disclaimer

This reference manual has been created as a tool to assist in the analysis process of the LPB. The user must read the entire contents of the manual as well as the applicable portions of the referenced materials. By using this manual, the user acknowledges and agrees that an understanding of the concepts contained in this manual are essential to the proper design of an LPB.

Final design and construction, for a specific application of an LPB, are the sole responsibility of the user. Anyone making use of this manual and its calculations does so at his or her own risk and assumes any and all liability resulting from such use.

The calculations shown within the manual are for preliminary use only and shall not be relied upon prior to review by a qualified Professional Engineer. A qualified Engineer is one that is familiar with the site conditions, project conditions, soil mechanics and the design theory as described in this manual. A final site and project specific design must be prepared by a registered Professional Engineer who is licensed in the state of the project.

ReCon Wall Systems, Inc. disclaims any and all expressed or implied warranties of merchantability or fitness for a particular purpose with regard to any and all use of this manual, its design calculations and with regard to any information or products contained or referred to herein.



LPB is produced and marketed pursuant
to a license agreement with:

ReCon Wall Systems, Inc.
7600 West 27th St., #229
St. Louis Park, MN 55426

Patents Issued: US 8,991,122 and US 9,624,640

Distributed by:

Visit lightpolebase.com for more information.